

Barrier Free Tolling

Press Briefing

1st March 2007

How will it work?

- Normal motorway flow
- No obstruction or effect on vehicles



Where will it be?

- On West-Link section of M50

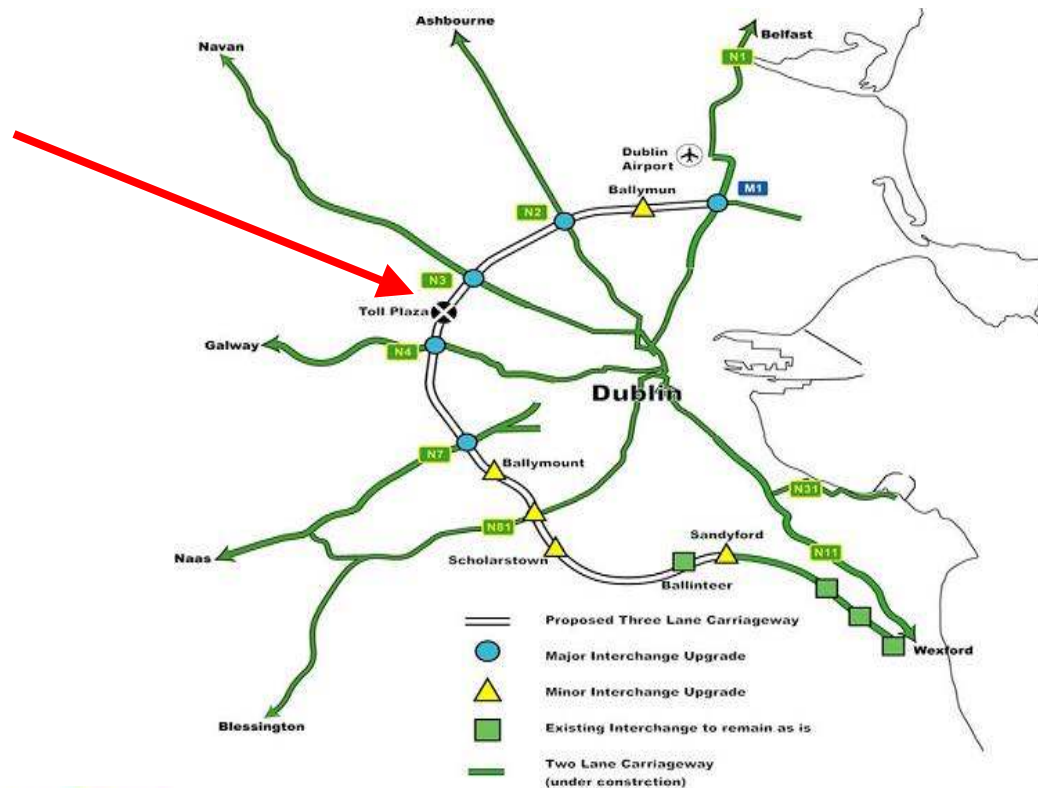

Technology

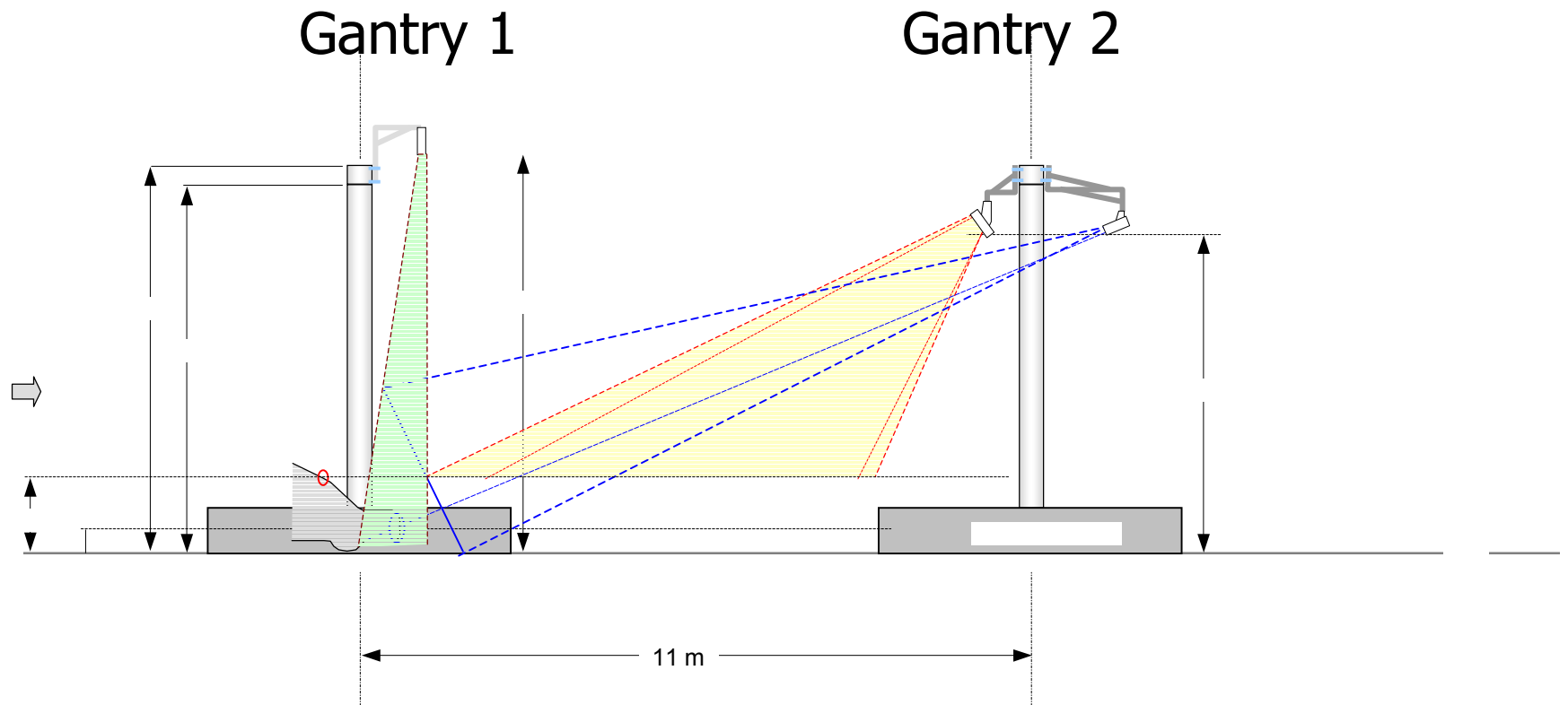

- 1st gantry detects vehicle
- 2nd gantry has antennae and cameras
 - 10 antennae, 11 cameras
- Electronic tag is read
- Number plate is read

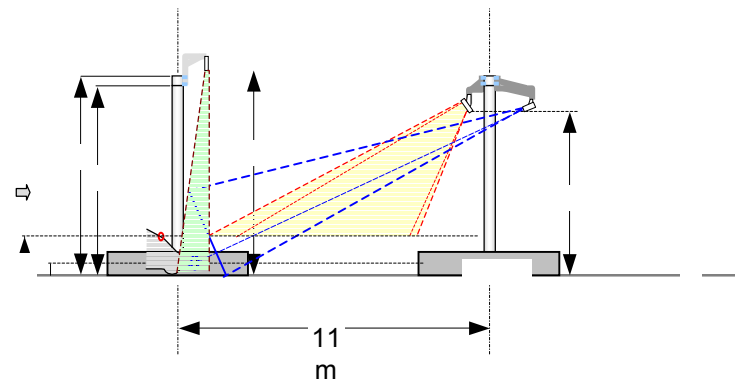



Links with other plazas

- All electronic tags will be usable on M50
- New M50 tag will be usable on all national toll plazas

Number plate reading

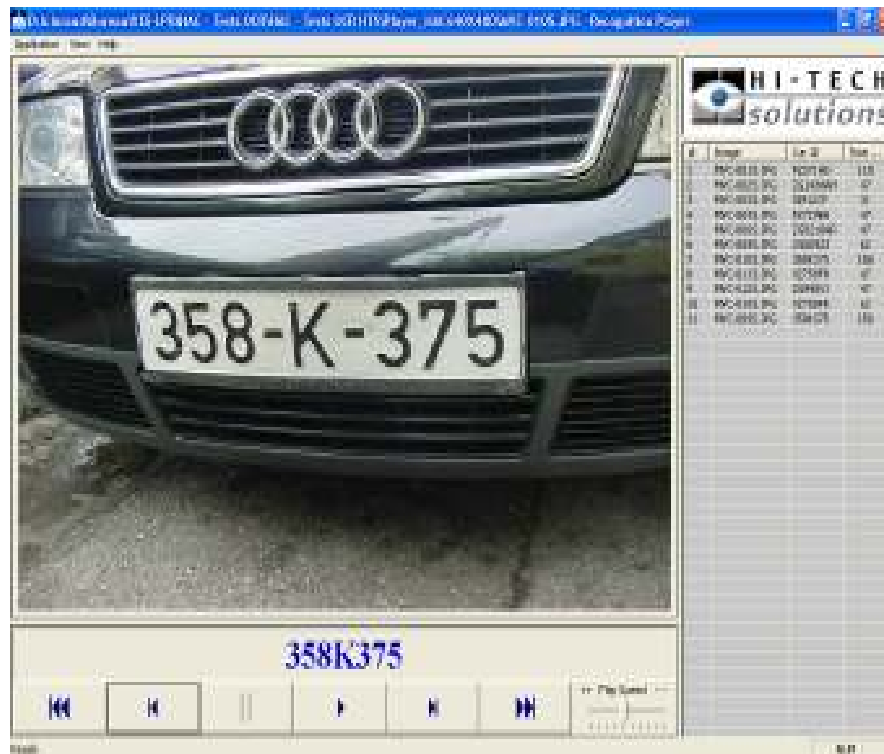

- Reads number plate in real time
- Connects with the National Vehicle Registration file in real time
- Generates a name and address and a charge

What will a road user have to do?

- Can register
 - as a Tag user
 - as a number plate user
 - All transactions will be automatically charged to customer account

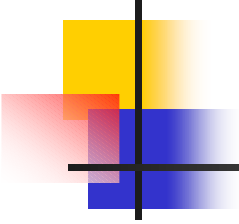
- 
-
- If not registered
 - Call the Contact centre and pay before 8pm next day or
 - Pay on receipt of letter



How can a user pay?

- Registered customers can choose either a pre-pay or post-pay option
 - Credit Card
 - Debit Card
 - Direct Debit
- Non-registered users can make payments via:
 - Online
 - Contact Centre
 - Retail Outlets



Charging

- Registered users will be charged a toll rate lower than the standard
 - Particular incentive for Tag users that reflects administrative efficiencies
- Non-registered users will be charged the standard toll rate
 - Maybe not registered because
 - choose not to
 - haven't registered yet
 - a 'one-time' user



Indicative arrangements

- Non- registered users who do not pay the toll by 8pm the following day will receive a payment request within 5 days for the standard toll plus an administrative fee
- Where payment is not received within 10 days, a second payment request will be issued which will be a multiple of the 1st payment request
- Payment to be made within 28 days



Enforcement

- Where bill remains unpaid after the time limit legal proceedings will commence



Customer Care

- Key lesson learned from other free-flow projects around the world
 - keep the user as a valued customer for as long as possible offering as many options as possible
- Contact Centre is key success factor



Contact Centre

- Aim
 - Provide a consistent high level of service resulting in a positive customer experience
- Best practice service level targets will apply
- Performance metrics set out in contract e.g.
 - Time to answer calls
 - First call resolution

Who will build and operate the system?

- BetEire Flow, a consortium comprising
 - **Sanef** the French toll operator and
 - **CS** the French systems designer, supplier and integrator
- **Sanef is** part of abertis, Europe's leading infrastructure group
 - has 40 years of experience in toll road operations, electronic toll collection and traffic management
 - manage toll services on 33% of all French motorways and 66% of Paris motorways and handle over 2.8m toll transactions per day.

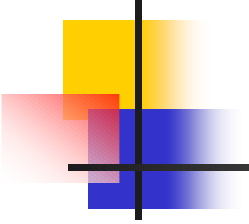
- 
- **CS** is ranked no. 3 in the world in intelligent transportation systems and leads in remote toll, free-flow and traffic management systems
 - In Feb 2007 CS and Sanef were awarded the Contract for the Golden Ears Bridge free-flow project in Vancouver
 - CS has experience in developing free-flow toll systems in North America (Virginia and California) and in France (A86 tunnel in Paris).



Who is advising the NRA?

- TÜV Rheinland are NRA's technical advisors
- Experience:
 - Advisors in the design, implementation and operation of the free-flow ETC systems for HGVs in **Germany** and **Austria**
 - Author of the technical specifications and requirements for both projects
 - Supervision of private companies throughout the installation and operation

TimeFrame: Constructing the System

■ **March to May 2007**

- Develop detailed specifications and system design for the M50 requirements
 - Roadside equipment
 - Front & back-office systems
 - Interface with national Vehicle File
 - Interface with Contact centre

■ **May 2007 to Jan 2008**

- Manufacturing and software development

■ **Nov 2007**

- Installation of gantries

■ **Dec 2007 to March 2008**

- Installation of antennae, cameras, roadside cabinets and equipment, cabling, communications links
- Manufacturing and delivery of on-board units

■ **April to June 2008**

- Testing of roadside systems
- Performance testing of other systems

Timeframe: Getting ready for operations

- Jan to April 2008
 - Operations staff recruitment and training
 - Toll operator staff
 - Contact centre staff
- April to June 2008
 - Trial operation
 - Consistent achievement of performance target of reading vehicles (but not yet charging)
 - Trial registration
 - Contact centre go-live
 - Registration facilities made available to public
- July 2008
 - Fine tuning
- August 2008
 - Go live



Comparison Timeframes

- **Free-Flow Golden Ears Bridge in Vancouver**
 - Contract Signed: Jan 2007
 - Design, Development, Factory Acceptance Test, and Construction of the Gantry: from Jan 2007 to Jan 2009 (23 months)
 - Access to the site (Gantry ready): Jan 2009
 - System Installation and Testing: From Jan 2009 to 1 July 2009 (6 months)
 - Start of Tolling: 1 August 2009
- **M50 Free-Flow**
 - Contract signed: March 2007
 - Design, Development, Factory Acceptance Test, and Construction of the Gantry: from March 2007 to Nov 2007 (9 months)
 - Access to the site (Gantry ready): Nov 2007
 - System Installation and Testing: From Dec 2007 to June 2008 (7 months)
 - Start of Tolling: 1 August 2008

Free-Flow on M50 to be achieved as fast as possible

Around the world

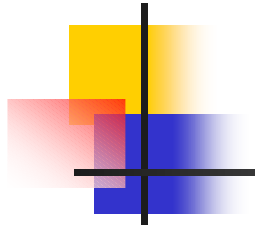

Toronto Austria, Germany (HGVs) Stockholm

California

Israel

Melbourne,
Sydney

Santiago

